

Features

- High reliability
- Superior linearity
- Thermo stability
- Easy-to-use detector/amplifier modules are also available

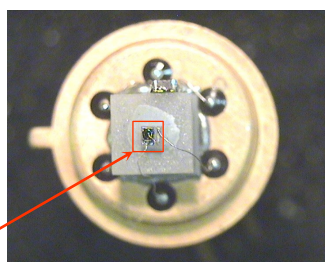

Photodiode CHIP

Description

Photodiode **PD36-02-TEC** is a model of photodetector for detection of radiation at room temperature in the Middle Infrared (Mid-IR) spectral range from 1500 to 3800 nm.

Photodiode **PD36-02-TEC** has thermo electric cooler (**TEC**) and termistor for a control of temperature. Components are integrated inside the standard 9.2 mm TO-5 package with **TEC**.

Diameter of the photosensitive area of **PD36-02-TEC** is 200 μm . High speed of response makes it possible for detection of modulated radiation of laser diodes (LDs) and light-emitting diodes (LEDs).

Related products: **PD36-02-TEC** can be used in optical pair with our **LED185...LED36**.

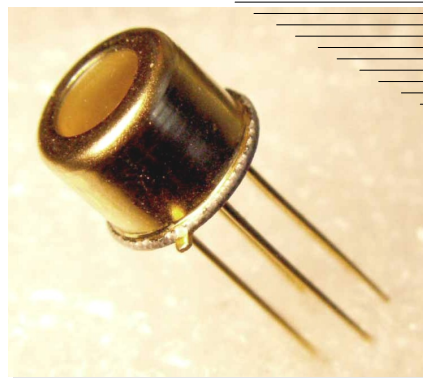

Applications

- Environment measurements
- Infrared spectrophotometry
- Laser detection
- Analytical instruments

Accessories (optional)

- Amplifier with temperature controller **AMT-07M**

General characteristics

Package	Parameter	Symbol	Value	Unit
TO-5 with TEC	Sensitive area diameter	d	0.2	mm
	Weight	m	1.15	g
	Operating temperature	T _{opr}	- 20...+ 40	°C
	Window material		sapphire glass	
	Cooling		one-stage TE-cooled	
	Soldering temperature	T _s	+ 230	°C
	Storage temperature	T _{stg}	- 20...+ 50	°C
	Maximum reverse bias voltage	V _b	- 1.0	V
	Size	D	9.2	mm
H		20.2		

Electrical and optical characteristics

Parameter	Symbol	Condition	Element temperature			Unit	
			- 20 °C	0 °C	+ 20 °C		
Spectral sensitivity range	λ	at level 10%	1.5* - 3.6	-	1.5* - 3.8	μm	
Peak sensitivity wavelength	λ_p	at level 90%	2.5 - 3.3	-	2.6 - 3.4	μm	
Photo sensitivity	S	at λ_p	1.0 - 1.2			A/W	
Detectivity	D^*	at λ_p	$[0.6 - 1.0] \cdot 10^{10}$	-	$[3 - 6] \cdot 10^9$	$\text{cm} \cdot \text{Hz}^{1/2} \cdot \text{W}^{-1}$	
Dark current	I_d	$V_b = -0.2 \text{ V}$	20 - 50	-	80 - 250	μA	
		$V_b = -0.4 \text{ V}$	70 - 100	-	140 - 400		
Capacitance	C	$V_b = 0 \text{ V}$, $f = 1 \text{ MHz}$	60 - 800			pF	
Rise time	t_r	$V_b = 0 \text{ V}$, $R_L = 50 \Omega$, $V_b = -0.5 \text{ V}$	10 - 100		10 - 15		ns
Fall time	t_f						
Shunt resistance	R_0	$V_b \approx \pm [5 - 10] \text{ mV}$	1.5 - 9.0	-	0.2 - 1.5	k Ω	
Noise equivalent power	NEP	at λ_p	-	-	-	$\text{W} \cdot \text{Hz}^{-1/2}$	

TEC TO506.1MC0400710.TB103 parameters (without load)

Parameter	Symbol	Condition	Value	Unit
Current power	I_{max}	ΔT_{max}	1.50	A
Voltage	U_{max}	ΔT_{max}	0.80	V
Cooling energy	Q_{max}	-	1.30	W
Temperature range	ΔT_{max}	vacuum	70	K
Termistor resistance	R_t	at + 20 °C	10.00	k Ω

* Not at level 10%

▼ Spectral response

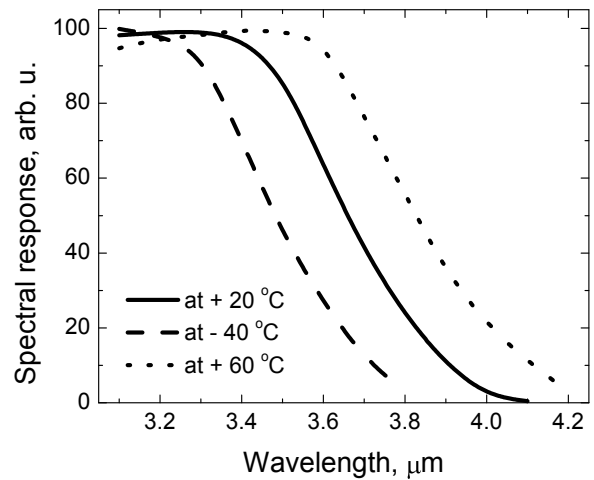
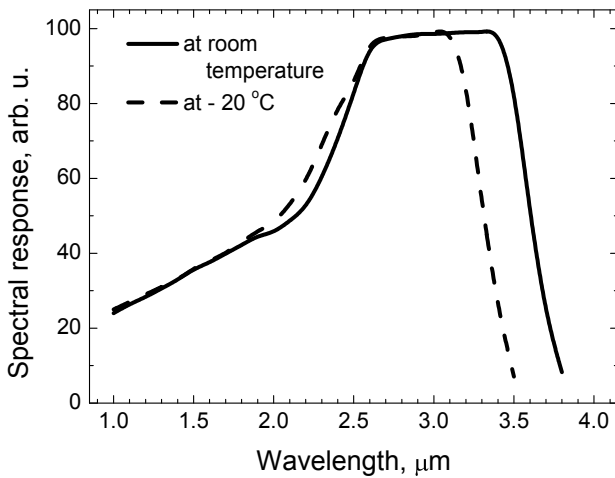

▼ Shunt resistance vs. element temperature

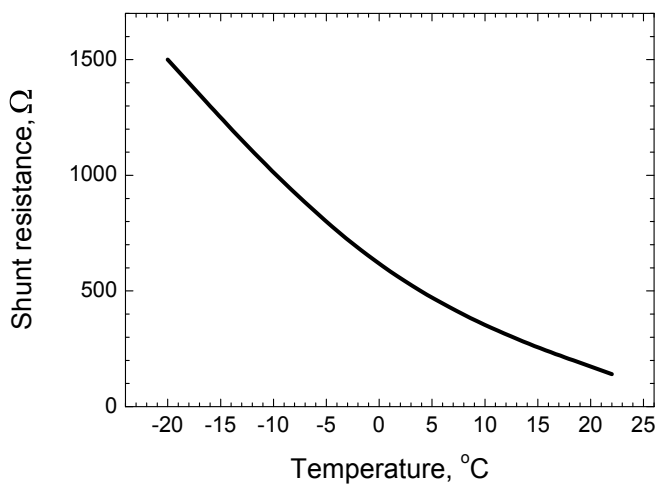

▼ Capacitance vs. reverse voltage

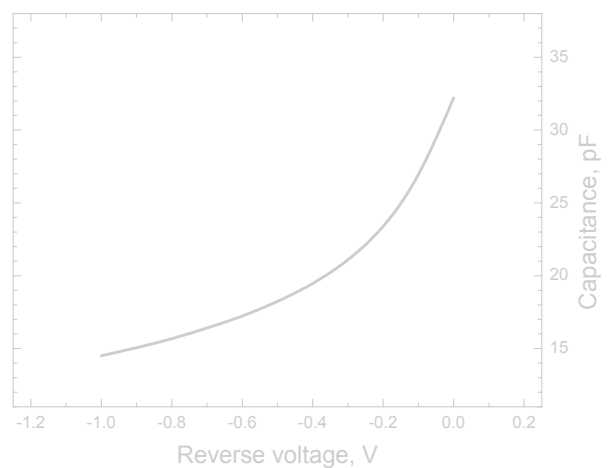

Dark current vs. reverse voltage

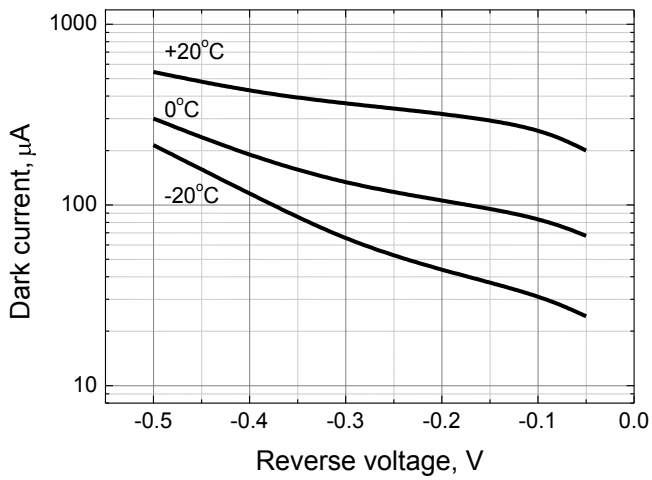

Thermoresistance vs. temperature

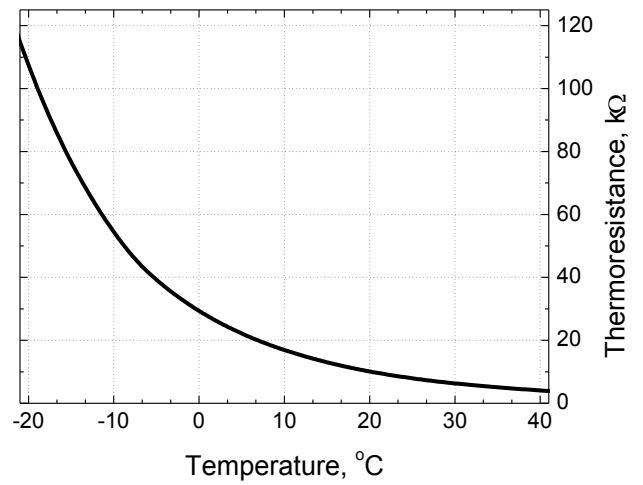

▼ TO-5 package with TEC dimensions (unit: mm)

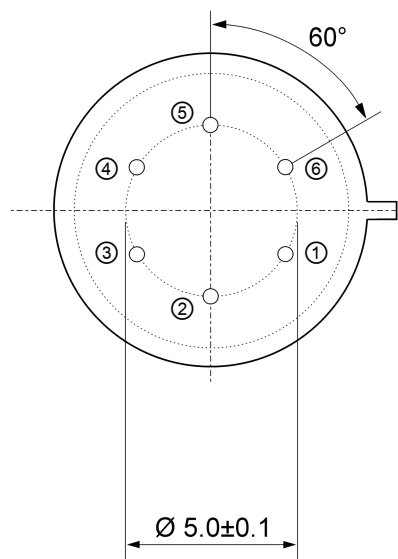
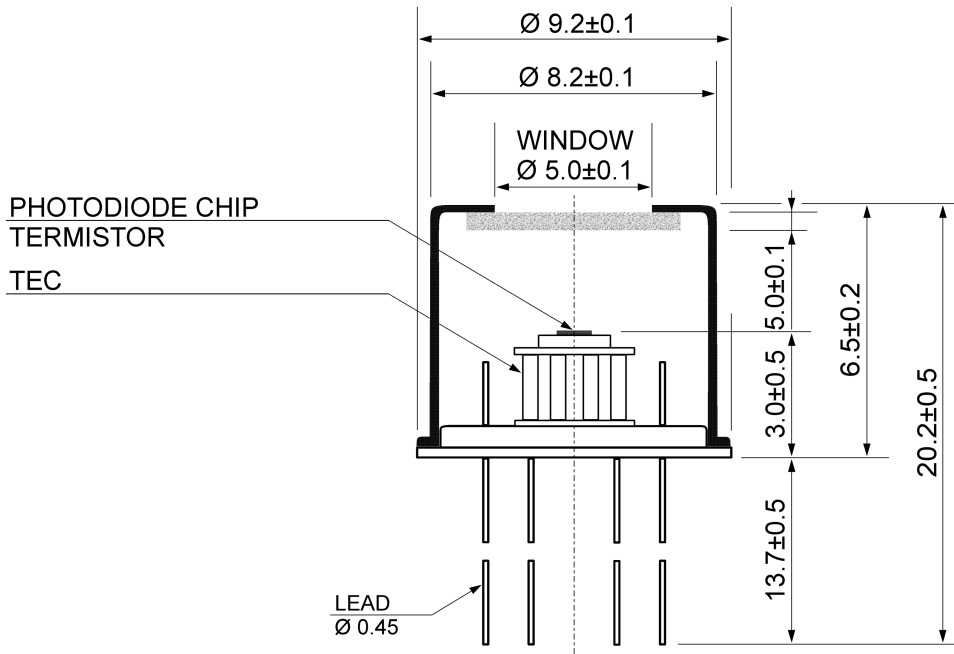

Pin	Description
①	TEC (anode)
②	Detector (anode)*
③	Detector (cathode)*
④	Termistor TC103
⑤	
⑥	TEC (cathode)

*Special order: the pin polarity can be changed.